

# MIL-STAK

LARGE BALE STACKERS

## Operator's Manual

PT/2016 Pull Type Bale Wagon

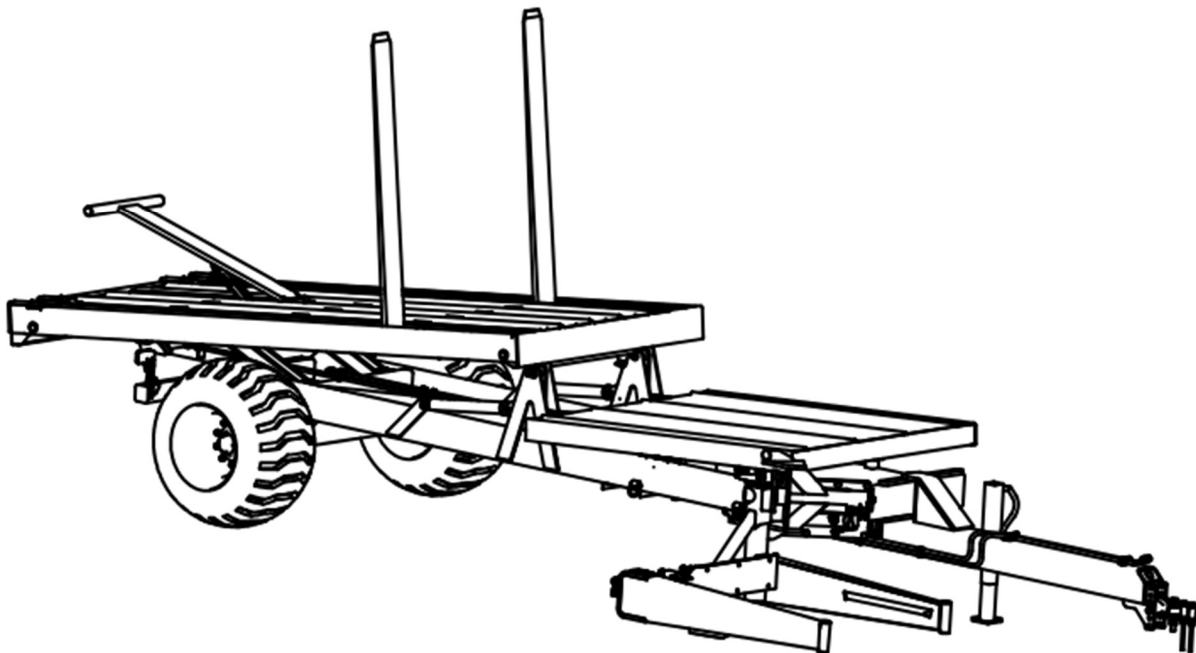

# Table of Contents

---

Introduction .....	4
PT/2016 Components.....	4
Joystick Functions .....	6
Display Functions.....	9
Screen Map.....	9
Logo Screen.....	10
Loading Screen .....	10
Counts Screen.....	12
Stack Pattern Screen .....	13
Totals Screen .....	14
Setup Screen .....	15
Machine Options Screen.....	16
Sensor Screen .....	17
System States Screen .....	18
Timing Screen.....	19
Display Options Screen .....	20
PT/2016 Sensors .....	22
Bale Clamp Sensors.....	22
Hitch Sensor .....	23
Receiving Table Sensors.....	23
Stack Bed Sensors .....	24
Rolling Rack Sensor .....	25
Pre-Operation Checklist .....	26
Operation.....	27
Preparing the PT/2016 for Loading .....	28

Loading in Automatic Mode .....	29
Loading in Manual Mode .....	31
Unloading in Automatic Mode .....	33
Unloading in Manual Mode.....	34
Bale Count Adjustment .....	35
Adjust Receiving Table Count .....	35
Adjust Stack Bed Count.....	35
Clear Customer Count .....	35
Lubrication.....	36
Maintenance .....	40
Maintenance Chart .....	40
Cleaning .....	40
First 50 Hours.....	41
Troubleshooting .....	42
Bale Clamp.....	43
Receiving Table.....	44
Stack Bed .....	45
Rolling Rack.....	45
Hitch.....	46

# Introduction

---

Congratulations on your purchase of a Mil-Stak PT/2016 Big Bale Wagon. Mil-Stak is dedicated to producing high quality stacking equipment that are fast, simple to operate, and affordable solutions for your stacking requirements. We sincerely hope you will enjoy many years of operation with your PT/2016.

## PT/2016 Components

We would like to start off by introducing the main components which make up the Mil-Stak PT/2016 Bale Wagon.

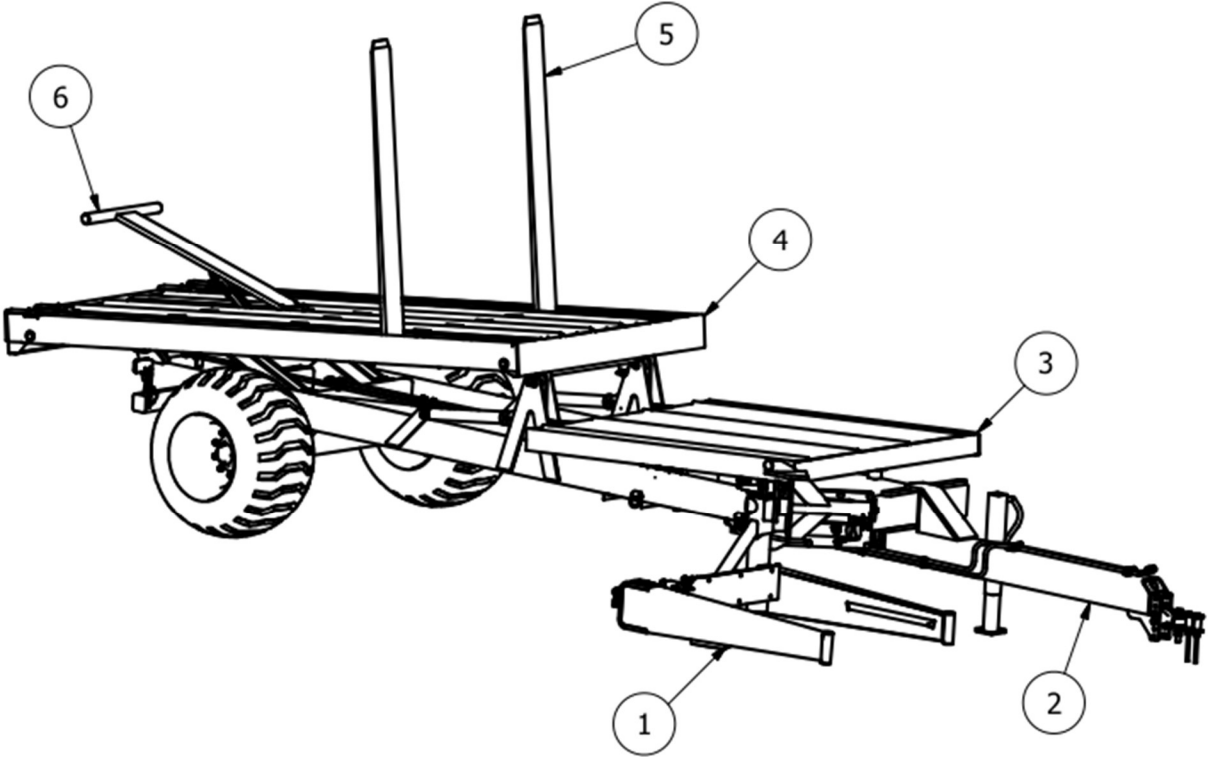

- 1. Bale Clamp:** The Bale Clamp picks up each bale from the field and places it gently on the Receiving Table. In automatic mode, the operator simply hits the bale at about five miles per hour then moves the joystick handle to the left which squeezes the bale in the Bale Clamp. Once clamping hydraulic pressure reaches a preset level, the computer takes over and places the bale gently on the Receiving Table.
- 2. Hitch:** The Hitch on the PT/2016 can be moved left or right using the joystick which allows the operator an extra level of precision and control when grabbing bales off the field. If the operator misjudges the location of a bale while lining up with it or needs to pull a bale out from underneath a pivot or wheel line, they can simple push the joystick handle forward or backwards to move the hitch left and right. This will in turn move the Bale Clamp left or right. The Hitch can also be moved completely to the left, aligning the left side of the PT/2016 with the center of the tractor cab, allowing the operator to line up the left side of the load with an existing stack.
- 3. Receiving Table:** The Receiving Table is where the individual bales are placed by the Bale Clamp. Once the Receiving Table is loaded with either two or three bales, depending on the size of bales being loaded, the Receiving Table transfers the bales to the Stack Bed. Each set of bales transferred from the Receiving Table to the Stack Bed is called a tier.
- 4. Stack Bed:** The Stack Bed is where each tier of the load is placed as bales are picked up off the field. Once fully loaded, the operator raises the Stack Bed 90° so it is in the vertical position then pulls away from the load, leaving the bales in a stack.
- 5. Rolling Rack:** The Rolling Rack is a pair of forks which roll to the front of Stack Bed when beginning a load. As the operator transfers each tier of bales onto the Stack Bed, the rolling rack moves towards the rear of the stack bed and keeps the bales from tipping over.
- 6. Pushoff:** The pushoff is used to assist in the unloading process if necessary by pushing the bales away from the machine. This prevents the forks from pulling the bottom bales away from the stack. It is activated by holding down the button on the joystick mount plate and retracts when the button is released.

## Joystick Functions

The included Joystick controls all of the functions on the PT/2016 Big Bale Stacker. In normal operation the PT/2016 should be operated in Automatic Mode to achieve the best performance and ease of use. In the off chance it is necessary to operate the PT/2016 manually, the necessary loading and stacking functions are easily carried out with the joystick while the machine is in manual mode.

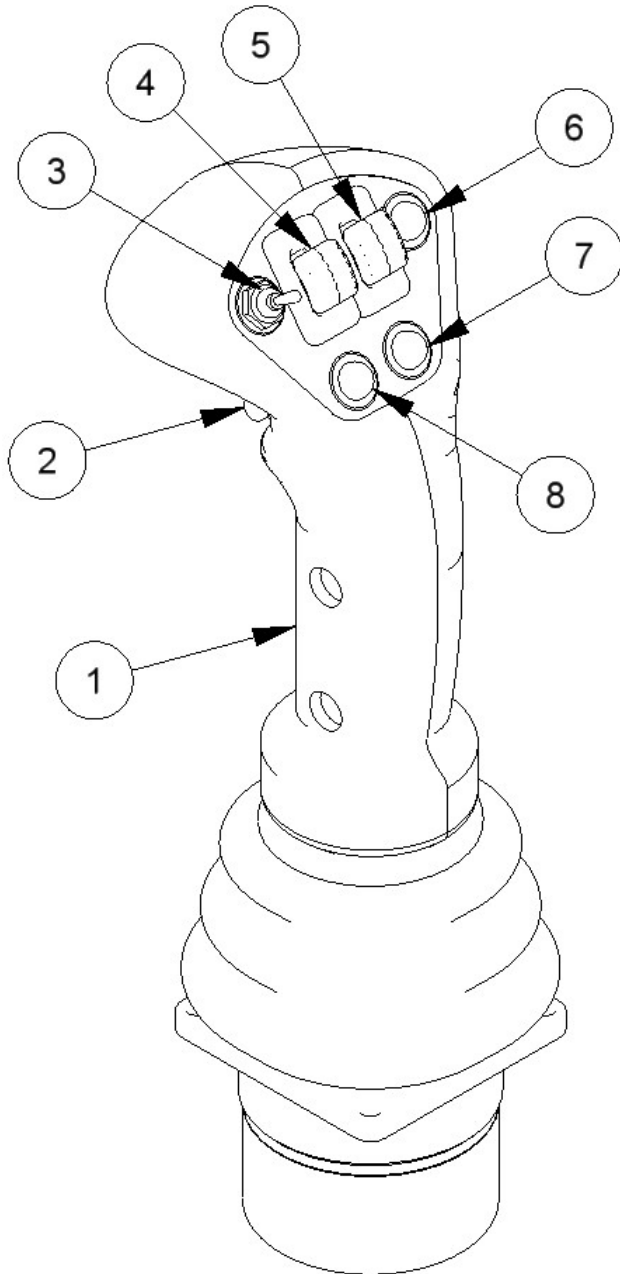

**1. Joystick Handle:** Moving the joystick handle to the right or left will open or close the Bale Clamp respectively. Moving the joystick handle forward or backward will move the hitch left or right respectively. These functions operate the same whether in manual or automatic mode. Movement of the Hitch and Bale Clamp will not begin until the Joystick Handle is moved more than 80% in any given direction. This prevents unintentional movement of the PT/2016 parts while driving over rough terrain with a hand on the Joystick.

**2. Trigger:** In manual mode, pressing and holding the trigger will raise Bale Clamp until released. Once released, the Bale Clamp will free fall downward. In automatic mode, pressing and releasing the trigger will automatically raise the Bale Clamp until it is resting above the Receiving Table. If the Bale Clamp is already in the resting position above the Receiving Table, the Bale

Clamp will automatically lower down to the loading position when the trigger is pressed and released.

3. **Rolling Rack 3-Way Switch:** Moving the Rolling Rack 3-Way switch forward or reverse will move the Rolling Rack forward or reverse respectively.

4. **Receiving Table Grip:** Moving the Receiving Table Grip forward or reverse will lower or raise the Receiving Table respectively. Moving the Receiving Table Grip more than 90% forward will initiate the Receiving Table Power Down function. This will lower the Receiving Table down faster as the Receiving Table is no longer free falling, but rather is being forced down with hydraulics. If the Receiving Table is powered all the way down, this may reduce the life of the seals on the hydraulic cylinders and support bumpers. The Receiving Table Grip will only move the Receiving Table in manual mode.

5. **Stack Bed Grip:** Moving the Stack Bed Grip forward or reverse in manual mode will lower or raise the Stack Bed respectively. In Automatic Mode, pulling the Stack Bed Grip back and holding it for two seconds will cause the Stack Bed raise to the preset position before stopping automatically. This allows you to focus on lining up with an existing stack while the Stack Bed automatically raises. Once the Stack Bed has reached the preset, up position and you would like to set the stack down on the ground, simply pull back gently on the Stack Bed Grip to raise the Stack Bed the rest of the way then drive forward to pull out from under the stack. If at any time you would like to stop the Stack Bed during the Automatic Raise sequence, simple move the Stack Bed Grip forward then release it. You can also switch the PT/2016 into manual mode to stop the movement. Moving the Stack Bed Grip forward and holding it for two seconds, while in automatic mode, will automatically lower the Stack Bed to the down position.

6. **Manual/Automatic Mode Button:** Pressing and releasing the Manual/Automatic Mode Button toggles the onboard computer between Manual and Automatic Mode. Switching from Automatic Mode to Manual Mode while any hydraulic cylinder is moving will stop all movement until switched back into automatic mode with the exception of the Bale Clamp. If the Bale Clamp is free falling it will continue to do so until it is in a resting position above the Receiving Table or in the down position.

7. **Automatic Unload Reset:** The Automatic Unload Reset button resets the PT/2016 Stack Bed, Rolling Rack, and Hitch to their normal positions. After you have set the load on the ground and have pulled away from the stack, press the Automatic Unload Reset button to initiate the Unload Reset sequence. Once initiated, this sequence will lower the Stack Bed for a few seconds to lift the rear end of the Stack Bed off the ground. After the rear of the Stack Bed is safely off the ground, the Hitch will begin to center and a short time later, the Rolling Rack will begin to move forward while the Stack Bed continues to lower to the down position. The Automatic Unload Reset sequence also adds the load count to the customer count at this time.

While in Manual Mode and the Count In Manual Mode option is turned on, pressing the Automatic Unload Reset button will add the Stack Bed Count to the Customer Count then clear the Stack Bed Count.

8. **Bale Clamp Hold:** The Bale Clamp Hold button will stop the movement of the Bale Clamp whether it is raising or lowering for as long as the Clamp Hold button is pressed. This is useful for avoiding a collision between your tractor tire and Bale Clamp when making a sharp, right hand turn and the Bale Clamp is lowering after placing a bale on the Receiving Table.

There is a setting in the Machine Options screen of the Display which allows you to turn on or off the Toggle Hold feature. When enabled and the operator presses then releases the Bale Clamp Hold button, the Bale Clamp will stop and hold its current position until the Bale Clamp Hold button or the Trigger is pressed. This is especially useful if the operator would like the Bale Clamp to maintain an elevated position for an extended period of time without having to continuously press the Bale Clamp Hold button. This option is turned on by default.



# Display Functions

## Screen Map

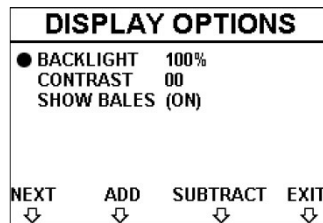
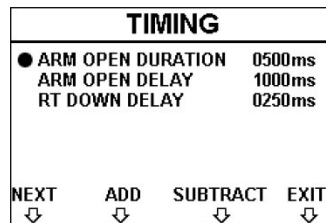
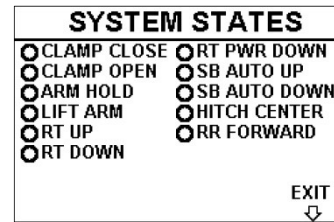
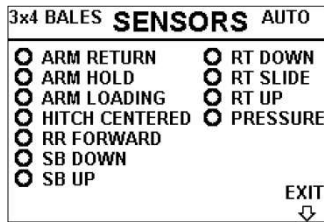
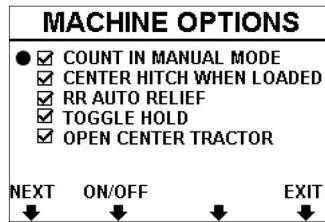
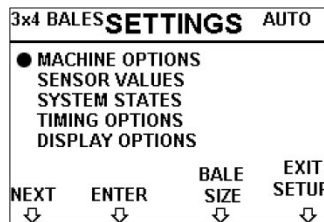
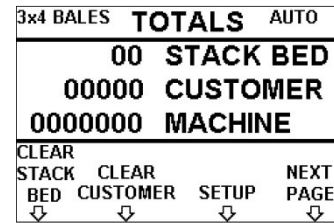
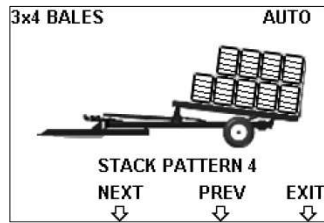
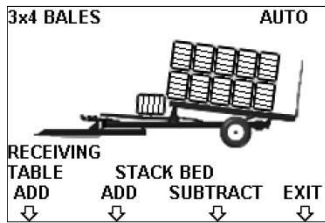
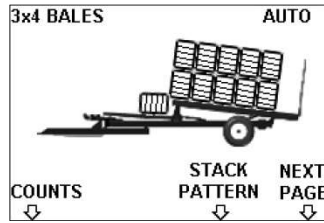

## Logo Screen



The logo screen is displayed when the PT/2016 starts up and shows the software version and the date the software was created on.

## Loading Screen

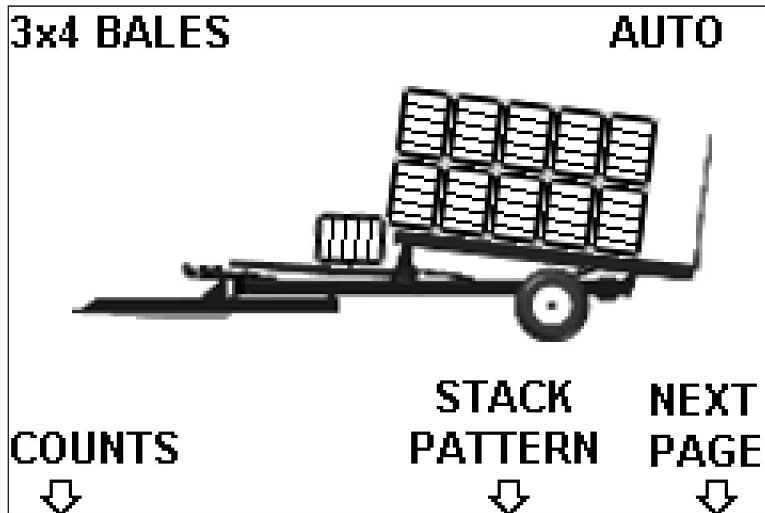

The Loading Screen is the main screen the operator will use during normal operation. It displays a visual representation of the number of bales on the Receiving Table and Stack Bed. From here you can switch to the Counts screen or Stack Pattern selection screen by pressing their respective buttons. Press the Next Page button to navigate to the Totals screen, access the machine settings, or change the bale size.

## Loading Screen Continued

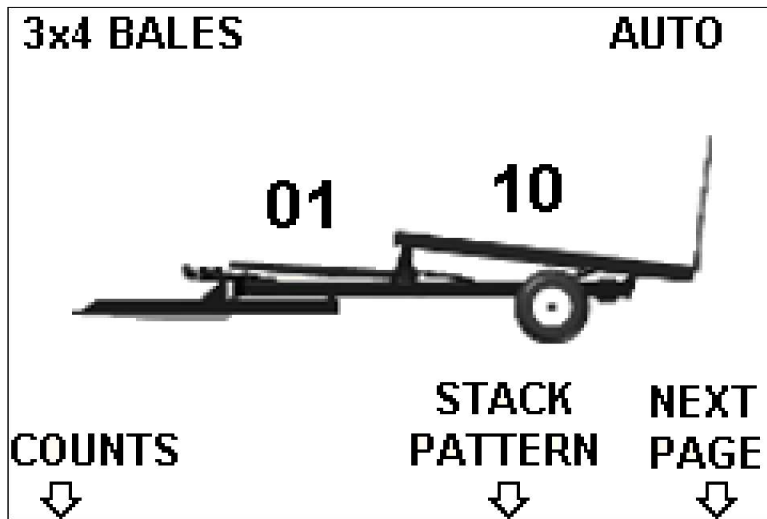

The display can also be configured to show numerical quantities of bales on the Receiving Table and Stack Bed instead of a visual representation of bales. To change this, navigate to the Totals Page, then to the Setup Page, then to the Display Options Page. From here, scroll down to the Show Bales option and press the On/Off button to toggle this setting.

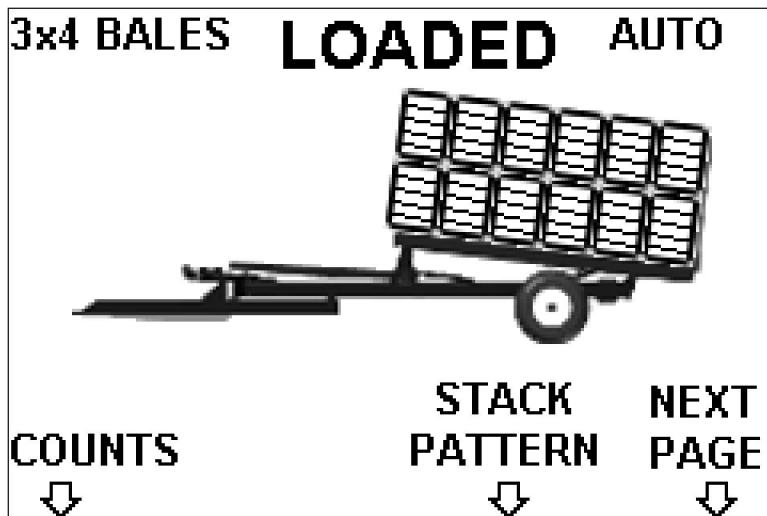

Once the PT/2016 is fully loaded, the Loading screen will display the text "LOADED" at the top, center of the screen as well as flash two green LED lights embedded in the display.

## Counts Screen

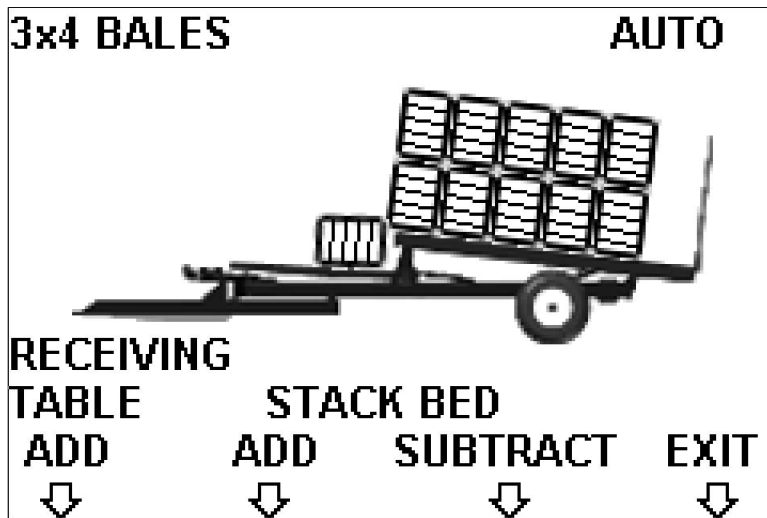

The counts of the Receiving Table and Stack Bed can be modified on this screen by pressing the Receiving Table Add, Stack Bed Add, and Stack Bed Subtract buttons. If the Receiving Table count is full and the Receiving Table Add button is pressed, the Receiving Table Count will reset to zero. Each time the Receiving Table Count is changed using the Display, the machine switches to Manual mode. When the operator returns the machine to Automatic mode, the Receiving table will cycle based upon the number of bales on the Receiving Table. This ensures the bales are in the correct location on the Receiving Table to prevent bales from being placed on top of one another.

## Stack Pattern Screen

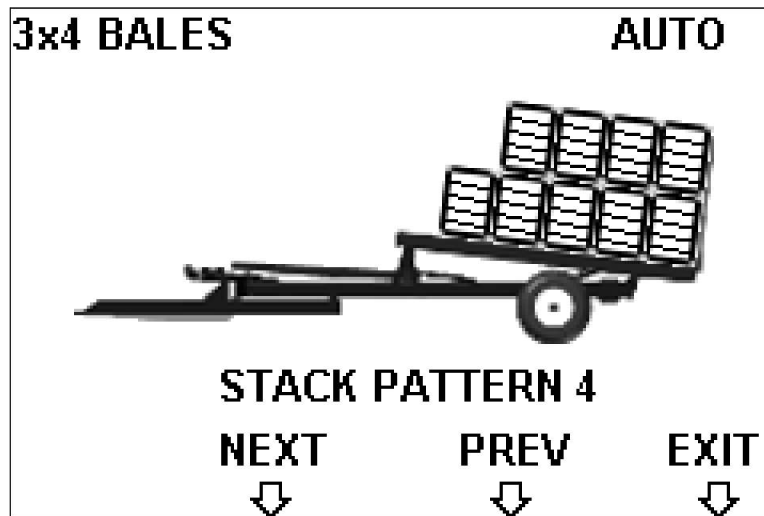

Different Stack Patterns can be selected on this screen. If you would like to create a starter stack or stacks shorter than the standard 4 or 6 high, navigate to this screen from the Loading Screen by pressing the Stack Patterns button then press the Next or Prev buttons to scroll through the available stack patterns. Once the desired Stack Pattern is displayed on the screen, press the Exit button to return to the Loading screen.

After the display is returned to the Loading screen, continue stacking as you normally would. When the Stack Bed count reaches the total number of bales for the selected Stack Pattern, the PT/2016 will automatically fold the clamp over the Receiving Table and indicate on the screen that the PT/2016 is fully loaded.

The previously used stack pattern is stored in the computer for each bale size. When switching between bale sizes, the computer automatically selects the last stack pattern used for that bale size.

## Totals Screen

3x4 BALES	<b>TOTALS</b>	AUTO
00	<b>STACK BED</b>	
00000	<b>CUSTOMER</b>	
0000000	<b>MACHINE</b>	
CLEAR		
STACK	CLEAR	NEXT
BED	CUSTOMER	PAGE
↓	↓	↓

The Totals Screen shows the number of bales on the Stack Bed, how many bales have been stacked for the current customer/field, as well as the total number of bales the PT/2016 has stacked over its life time.

On this screen, the operator can clear the Stack Bed Count, clear the Customer Count, access the Setup Screen, or return to the Loading Screen.

Pressing the Clear Stack Bed button will reset the Stack Bed Count to zero. If the Count In Manual Mode option is turn on, clearing the Stack Bed Count will automatically add the Stack Bed Count to the Customer Count before clearing. The Count In Manual Mode setting can be accessed by pressing the Setup button, then by entering the Machine Options Screen.

Pressing the Clear Customer button resets the Customer Count to zero. The Customer Count can be used for keeping track of bales stacked for a single customer or it can be used to keep track of how many bales were stacked for a single field.

Pressing the Setup button enters the Setup Screen where the PT/2016's settings and troubleshooting screens are located.

Press the Next Page button to return to the Loading Screen.

## Setup Screen

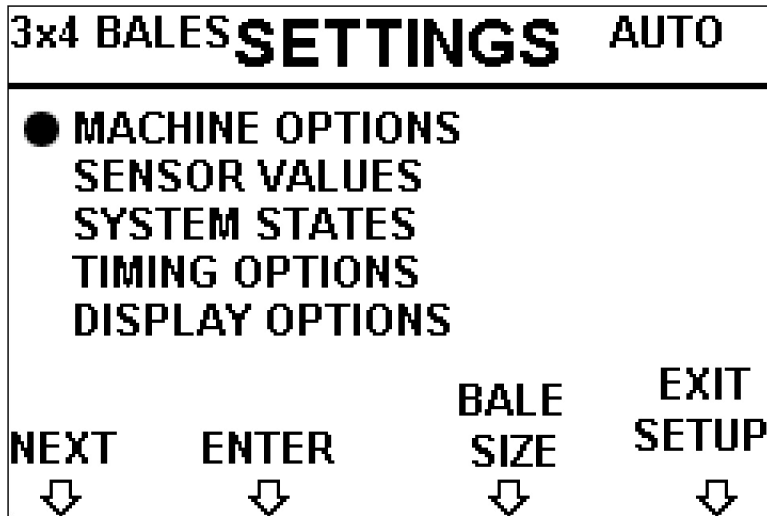

The Setup Screen displays the currently selected bale size as well as allows the operator to access the available settings and troubleshooting screens.

Pressing the Next button will cycle the selection indicator through the list of settings and troubleshooting screen options. Once the selection indicator is in line with the desired screen, pressing the Enter button will switch to the selected screen.

Pressing the Bale Size button will cycle through the three bale size options, 3x3 Bales, 3x4 Bales, and 4x4 Bales. The computer on the PT/2016 will remember this setting until it is changed, even after cycling the power to the PT/2016.

Pressing the Exit Setup button will return the display to the Loading Screen.





## Machine Options Screen

### MACHINE OPTIONS

---

- COUNT IN MANUAL MODE
- CENTER HITCH WHEN LOADED
- RR AUTO RELIEF
- TOGGLE HOLD
- OPEN CENTER TRACTOR

NEXTON/OFFEXIT



The Machine Options screen allows the operator to enable or disable various settings on the PT/2016 to customize its operation to best suit individual needs.

Similar to the Setup Screen, the Machine Options Screen has a selection indicator which cycles through the various settings when the Next button is pressed. Once the desired setting has been selected, press the On/Off button to toggle the setting on or off.

The **Count In Manual Mode** option allows the PT/2016 to automatically count bales in Manual Mode. This is useful if you will be loading bales onto the PT/2016 on extreme hills or other rare conditions where loading manually may be preferred or necessary.

The **Center Hitch When Loaded** option, when turned on, will cause the PT/2016 to automatically center the Hitch once the last bale of a full load has been transferred to the Stack Bed. This option is enabled by default.

The **RR Auto Relief** option, when turned on, commands the Rolling Rack to move towards the rear of the Stack Bed once the Receiving Table has begun lifting a tier of bales, transferring them from the Receiving Table to the Stack Bed. This setting is for situations where bales tend to ride up about a foot above the Stack Bed then drop to hard onto the Stack Bed when transferring bales from the Receiving Table to the Stack Bed. This typically happens when loading 4x4 bales or when the bales are wet and sticky.



## Machine Options Screen Continued

The **Toggle Hold** option changes the functionality of the Bale Clamp Hold button. When enabled and the operator presses then releases the Bale Clamp Hold button, the Bale Clamp will stop and hold its current position until the Bale Clamp Hold button or the Trigger is pressed. If the Toggle Hold setting is turned off, the Bale Clamp will stop and hold its current position only while the operator is pressing the Bale Clamp Hold button. Once the Bale Clamp Hold button is released, the Bale Clamp will free fall to its resting position either down toward the ground or above the Receiving Table. The Toggle Hold option is turned on by default.

Pressing the Exit button will return the Display to the Setup Screen.

## Sensor Screen

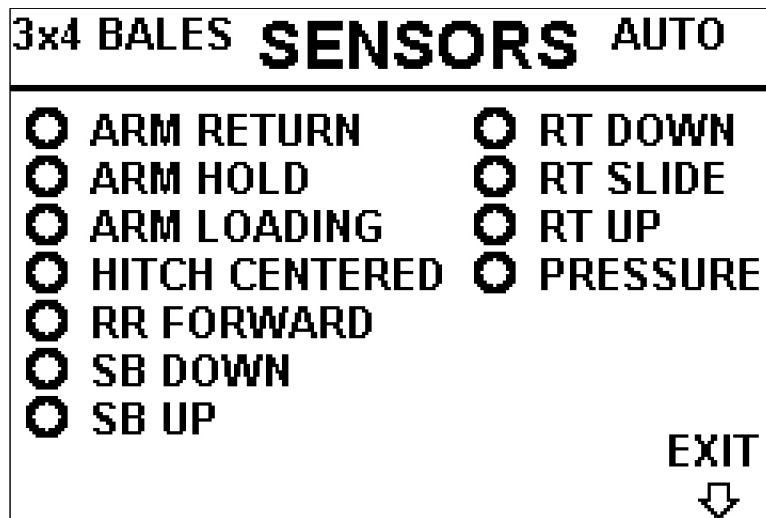

The Sensors Screen allows the operator to view the current state of each sensor on the PT/2016 in real time. If a sensor is not detecting a metal target in front of it, the corresponding sensor indicator on the display will be a hollow circle. If a sensor detects a metal target in front of it, the corresponding sensor indicator will be displayed on the screen as a solid circle. This screen is use for troubleshooting problems that may arise.

Pressing the Exit button will return the Display to the Setup Screen.

## System States Screen

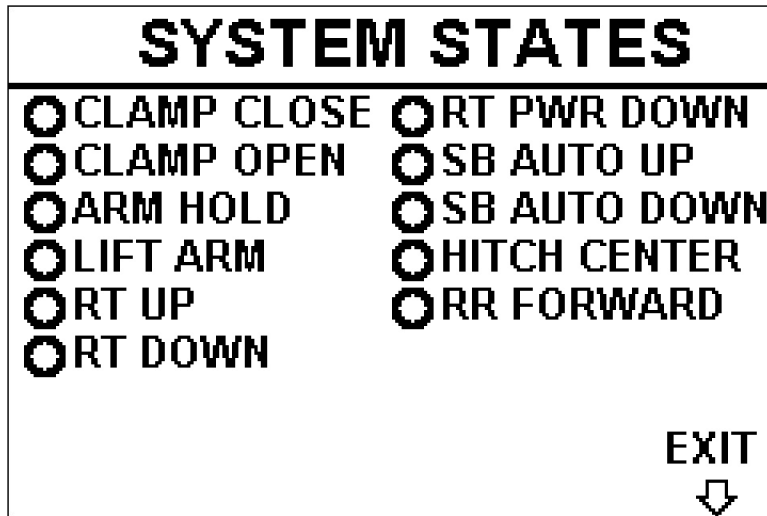

Much like the Sensor Screen, the System States Screen displays the various systems states the PT/2016 goes through during normal operation. When a given system state is active within the PT/2016's onboard computer, the corresponding indicator will become a solid circle. This is useful when troubleshooting the PT/2016 as it allows you to see exactly what the PT/2016 is doing.

Pressing the Exit button will return the Display to the Setup Screen.

## Timing Screen

TIMING			
● ARM OPEN DURATION	0500ms		
ARM OPEN DELAY	1000ms		
RT DOWN DELAY	0250ms		
NEXT	ADD	SUBTRACT	EXIT
↓	↓	↓	↓

The Timing Screen allows the operator to adjust a few of the PT/2016's time delays in order for the operator to achieve optimal performance for the current conditions of the field and bales.

Pressing the Next button cycles the selection indicator through the list of available timing settings.

Pressing the Add or Subtract buttons will increase or decrease the time duration of the selected timing option respectively.

The **Arm Open Duration** adjusts the amount of time the Bale Clamp opens for. Operators of tractors with lower hydraulic flows and/or pressures may need to increase the amount of time the clamp opens just as operators of tractors with higher hydraulic flows and/or pressures may need to reduce the amount of time the clamp opens.

The **Arm Open Delay** allows the operator to adjust the duration of time that the Bale Clamp free falls before opening the Bale Clamp. If the cushion valve is adjusted to a loose setting where the bales are lowered onto the Receiving Table quickly, the operator may want to decrease the amount of time that passes before the clamp opens. Likewise, if this time duration is set too low, the Bale Clamp will release the bale before the bale has made contact with the Receiving Table. The operator would likely want to increase the time duration to prevent damage to the Receiving Table.

## Timing Screen Continued

The **RT Down Delay** adjusts the amount of time the Receiving Table holds at the slide position before lowering to the down position. If the bales being loaded onto the PT/2016 are sticky or wet, they don't slide as easily on the Receiving Table. Increasing the RT Down Delay will allow more time for the bales to slide towards the rear of the Receiving Table. If this value is set too low, the bales will not reach the back of the Receiving Table and any subsequent bales placed on the Receiving Table will likely be placed on top of an existing bale.

Pressing the Exit button will return the Display to the Setup Screen.

## Display Options Screen

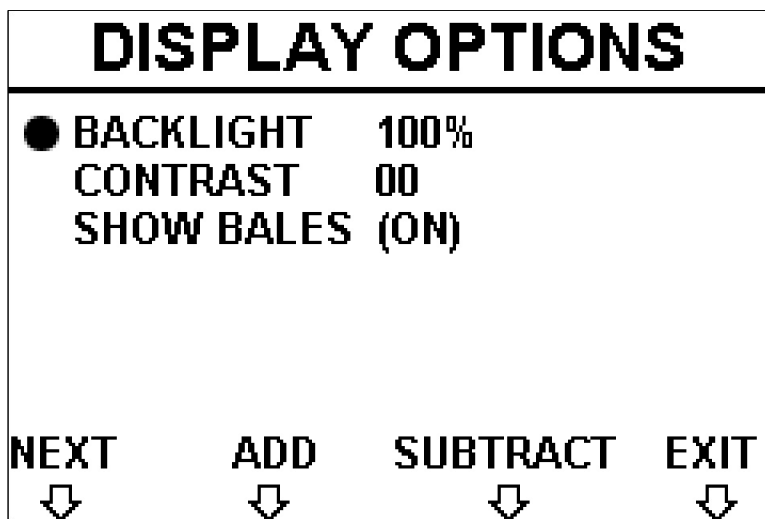

The Display Options Screen allows the operator to adjust three settings of the Display.

Pressing the Next button will cycle the selection indicator through the available settings on the Display Options Screen.

If the selection indicator is in line with the Backlight or Contrast settings, Add and Subtract button labels will be displayed on the screen.

Pressing the Add or Subtract buttons will increase or decrease the Backlight or Contrast values respectively.

If the selection indicator is in line with the Show Bales setting, an On/Off text label will be displayed on the screen.

Pressing the On/Off button will toggle the Show Bales option on or off.

The **Backlight** setting adjusts the brightness of the Display's integrated Backlight. If the operator is stacking bales at night, it might be preferable to decrease the brightness of the Backlight for better field visibility.

The **Contrast** setting adjusts the Display's contrast.

The **Show Bales** option modifies the appearance of the Loading Screen. If the Show Bales option is turned on, images of bales are displayed on the Loading Screen to indicate the quantity of bales on the PT/2016. If this option is turned off, numerical values are displayed on the Loading Screen to indicate the quantity of bales on the PT/2016. By default, the Show Bales option is turned on.

Pressing the Exit button will return the Display to the Setup Screen.

## PT/2016 Sensors

There are ten inductive proximity sensors on the PT/2016. Each sensor has an LED light built into it which turns on when the sensor detects a metallic object in front of it. Below are the locations of each sensor, sensor bracket, and sensor target, as well as the description of their functions.

### **Bale Clamp Sensors**

**1. Bale Clamp (Arm) Loading Sensor:** The Arm Loading Sensor tells the onboard computer when the Bale Clamp has reached the top dead center position while loading a bale onto the Receiving Table.

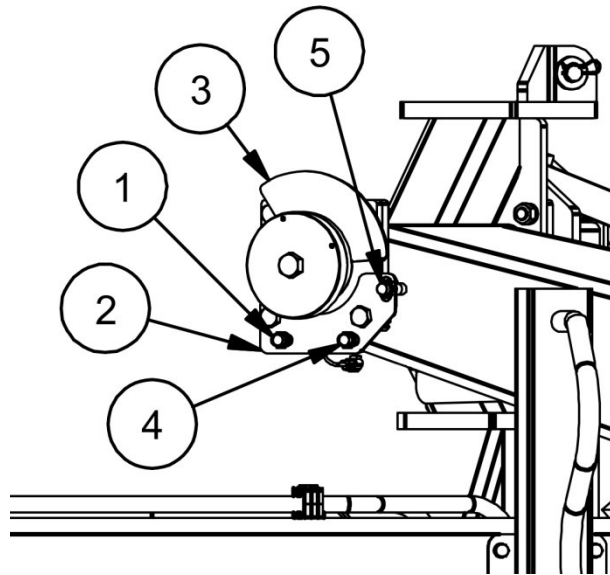

**2. Bale Clamp Sensor Bracket:** The Bale Clamp Sensor Bracket holds each of the three Bale Clamp Sensors in place.

**3. Bale Clamp Sensor Target:** The Bale Clamp Sensor Target moves in front of each sensor as the Bale Clamp raises and lowers.

**4. Bale Clamp (Arm) Hold Sensor:** The hold sensor tells the onboard computer when the Bale Clamp has reached the holding position. If a bale has been clamped before the Receiving Table has lowered to the down position, the PT/2016 will hold the bale in the air until the Receiving Table has returned to the down position.

**5. Bale Clamp (Arm) Return Sensor:** The return sensor tells the onboard computer when the Bale Clamp has reached the top dead center position after placing a bale onto the Receiving Table.

## Hitch Sensor

**6. Hitch Sensor:** The Hitch Sensor tells the onboard computer when the Hitch is moved over to the far right position. When in this position, the PT/2016 is centered behind the tractor.

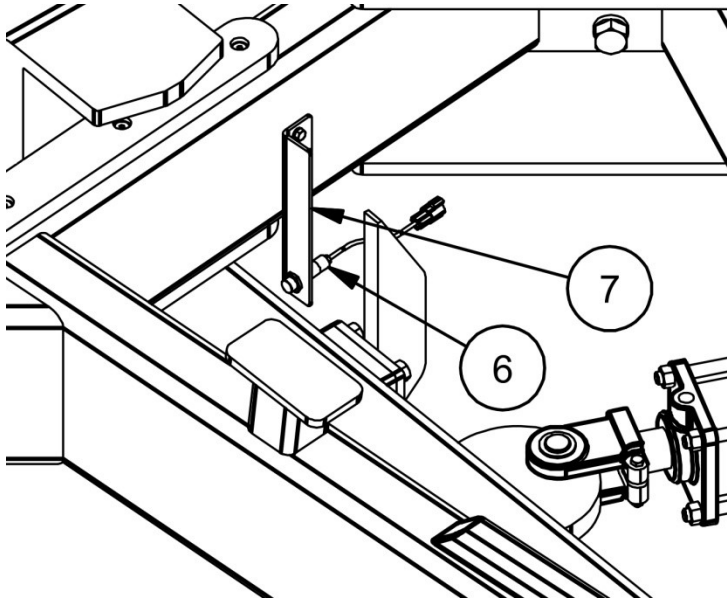

**7. Hitch Sensor Bracket:** The Hitch Sensor Bracket mounts to the frame of the PT/2016 and holds the Hitch Sensor in place.

## Receiving Table Sensors

**8. Receiving Table Target:** The Receiving Table Target moves in front of the Receiving Table Sensors as the Receiving Table moves up and down. This allows the onboard computer to know if the Receiving Table is up, down, or at the slide position.

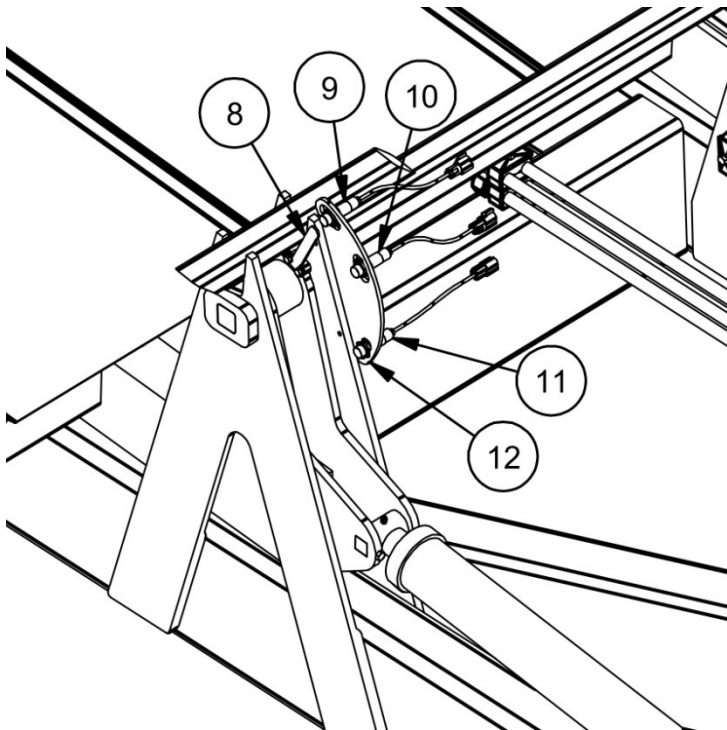

**9. Receiving Table Down Sensor:** The Receiving Table Down Sensor tells the onboard computer when the Receiving Table is in the down position.

**10. Receiving Table Slide Sensor:** The Receiving Table Slide Sensor tells the onboard computer when the Receiving Table has reached

the slide position.

**11. Receiving Table Up Sensor:** The Receiving Table Up Sensor tells the onboard computer when the Receiving Table is in the up position.

**12. Receiving Table Sensor Bracket:** The Receiving Table Sensor Bracket holds each of the three Receiving Table Sensors in place. This bracket is slotted to allow you to adjust the sensor locations and thus adjust where the Receiving Table stops at each of the three locations.

### Stack Bed Sensors

**13. Stack Bed Down Sensor:** The Stack Bed Down Sensor tells the onboard computer when the Stack Bed is in the down position.

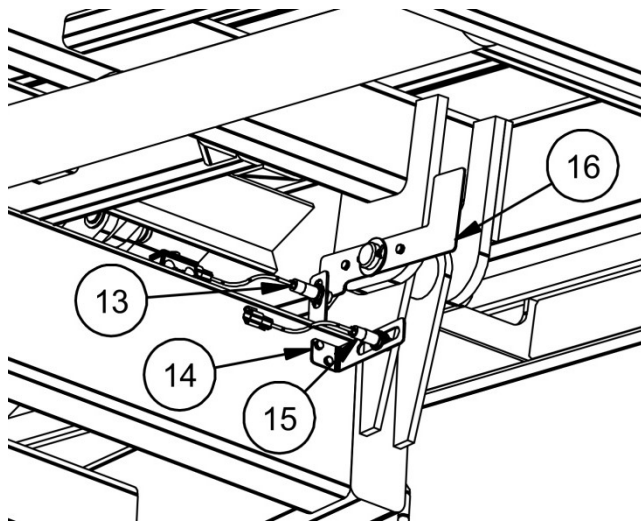

**14. Stack Bed Sensor Bracket:** The Stack Bed Sensor Brackets hold the Stack Bed Sensors in place. They are slotted to allow you to adjust the up and down positions of the Stack Bed.

**15. Stack Bed Up Sensor:** The Stack Bed Up Sensor tells the Stack Bed where to stop when you initiate the Automatic Unload Sequence. The Stack Bed Up Sensor should be adjusted so the rear of the Stack Bed stops about 3–5 inches above the ground when loaded

**16. Stack Bed Sensor Target:** The Stack Bed Sensor Target rotates with the Stack Bed to allow the onboard computer to know when the Stack Bed is in the up or down position.



## Rolling Rack Sensor

**17. Rolling Rack Forward Sensor:** The Rolling Rack Forward Sensor tells the onboard computer when the Rolling Rack is at the front of the Stack Bed.

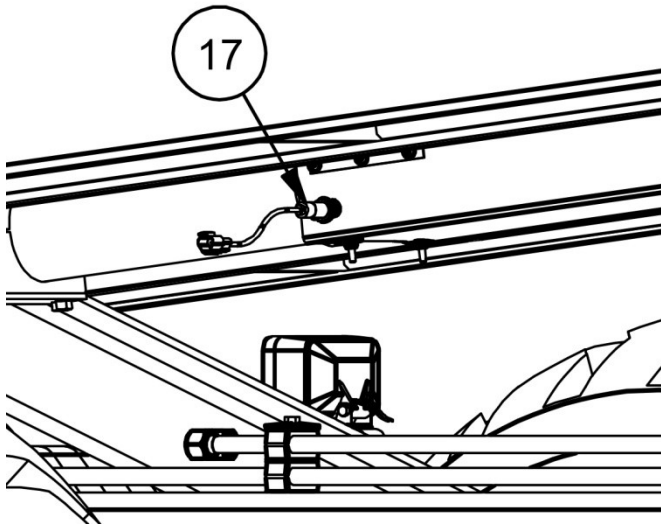

## Pre-Operation Checklist

---

Each time before operating the PT/2016, it is necessary to follow the Pre-Operation check list below to ensure the proper functionality of the equipment.

- Tire Pressure: Ensure tires are inflated to the factory recommended pressure. See Page 40
- Lubrication: Lubricate all grease points at the recommended time intervals before operation. See Page 36
- Lighting: Check for proper function of all signal, side marker, and works lights.
- Hitch Ball: Ensure that the hitch is securely fastened to the draw bar of the tractor before operation. Loose fasteners can lead to a shorter lifespan of the hitch ball.
- Ensure Port, Tank, and Load Sense (if required) hydraulic hoses are connected securely.

# Operation

---

Mil-Stak has taken great care when designing the PT/2016's control system to ensure the simplicity and efficiency of operation even for a new user. As you will see, there are only a few joystick functions needed to begin stacking bales in automatic mode.

## **Preparing the PT/2016 for Loading**

Before you begin loading it is recommended that you run through the Pre-Operation Checklist on page 26 to ensure the PT/2016 is ready to begin operation. Failure to do so can lead to excessive wear and machine failure.

When driving on roads between locations, it is recommended that the Bale Clamp be stowed in the up position above the Receiving Table. This prevents the Bale Clamp from colliding with mail boxes, power poles, fences, and other objects on the right side of the wagon. Centering the hitch so that the PT/2016 is directly behind the tractor is also recommended while driving to and from stacking locations as well as through the field.

Once you are in the field and are ready to begin loading, follow these steps to prepare the PT/2016 for loading:

1. Ensure the Bale Clamp is free of ground obstructions before lowering it to the down position.
2. If the PT/2016 is in manual mode, press the Manual/Automatic Mode Button on the Joystick to switch the system to Automatic Mode.
3. Press, then release the Joystick Trigger Button to lower the Bale Clamp to the down position.
4. Ensure the Stack Bed is completely down. If it is not, push the Stack Bed Grip forward for two seconds to automatically lower the Stack Bed.
5. Ensure the Rolling Rack is completely forward. If it is not, push the Rolling Rack 3-Way Switch forward until the Rolling Rack is completely forward.
6. Ensure the PT/2016 computer has the correct bale size selected. The bale size is shown in the upper left corner of the display on the Loading Screen and the Totals Screen. To change the bale size, navigate to the Totals Screen, then press the Setup button. On the Setup Screen, press the Bale Size button until the correct bale size is displayed in the upper left corner of the display. Press the Exit Setup button to return to the Totals Screen then press the Next Page button to return to the Loading Screen.

## **Loading in Automatic Mode**

The PT/2016 has been designed from the ground up to operate entirely in Automatic Mode for the greatest ease and efficiency while loading and unloading. It is recommended that the operator always loads and unloads in Automatic Mode to get the most out of the Mil–Stak PT/2016.

After you have completed all of the steps on page 28 to ensure the Mil–Stak PT/2016 is ready to begin loading, the following steps will walk you through the typical automatic loading sequence. When loading bales onto the PT/2016, it is recommended to drive no more than 5 mph as you make contact with each bale. Driving at speeds faster than 5 mph when making contact with bales can damage the PT/2016.

1. Before reaching the first bale in the field, make sure the Bale Clamp is opened far enough to allow a bale to fit in the clamp. Move the Joystick Handle to the right to open the Bale Clamp if it is not opened far enough.
2. While driving through the field at about 5 mph, line up the Bale Clamp with the bale you would like to load onto the PT/2016.
3. Once you make contact with the bale, move the Joystick Handle to the left. This closes the Bale Clamp on the bale. Continue holding the Joystick Handle to the left until the computer takes over and begins to lift the bale off the ground. Once the hydraulic pressure on the Bale Clamp reaches 900 PSI, the computer automatically takes over and places the bale on the Receiving Table. Once the bale is on the Receiving Table and the Bale Clamp is safely out of the way, the computer will raise the Receiving Table half way to slide the bale to the rear of the Receiving Table then lower it back down.
4. Continue loading bales until the Receiving Table is full. When stacking 3x3 bales, you will place three bales on the Receiving Table before the computer automatically transfers the bales from the Receiving Table to the Stack Bed. If you are stacking 3x4 or 4x4 bales, you will place two bales on the Receiving Table before the computer automatically transfers the bales from the Receiving Table to the Stack Bed.

5. Continue loading bales until the Stack Bed is completely full. When stacking 3x3 bales, the Stack bed will hold 18 bales. If you are stacking 3x4 bales, the stack bed will hold 12 bales. If you are stacking 4x4 bales, the Stack Bed will hold 8 bales. Once the Stack Bed is fully loaded the Display will indicate that the PT/2016 is fully loaded by displaying “LOADED” on the Loading Screen. Green LED lights will also flash on the display to indicate the PT/2016 is fully loaded.
6. Once the PT/2016 is fully loaded the Bale Clamp will automatically fold over the Receiving Table after the Receiving Table is completely down.
7. If the Center Hitch When Loaded setting is turned on, the PT/2016 will automatically center the Hitch once a full load is achieved. If this option is turned off, center the Hitch by pulling the Joystick Handle backwards before driving to the location where you will unload the PT/2016. Once the Hitch is centered, release the Joystick Handle.

You are now ready to drive to the stack yard and begin the Automatic Unloading Sequence.

## **Loading in Manual Mode**

As mentioned in the previous section, the PT/2016 has been designed from the ground up to operate entirely in Automatic Mode for the greatest ease and efficiency while loading and unloading. If for some reason there is a malfunction with any of the sensors or you wish to operate the PT/2016 in manual mode due to field conditions, all of the functions of the PT/2016 can easily be carried out manually with the Joystick.

After you have completed all of the steps on page 28 to ensure the Mil-Stak PT/2016 is ready to begin loading, these next steps will walk you through the typical manual loading sequence. When loading bales onto the PT/2016, it is recommended to drive no more than 5 mph as you make contact with each bale. Driving at speeds faster than 5 mph when making contact with bales can damage the PT/2016.

1. Before reaching the first bale in the field, make sure the Bale Clamp is opened far enough to allow a bale to fit in the clamp. Move the Joystick Handle to the right to open the Bale Clamp if it is not opened far enough.
2. While driving through the field at about 5 mph, line up the Bale Clamp with the bale you would like to load onto the PT/2016.
3. Once you make contact with the bale, move the Joystick Handle to the left. This closes the Bale Clamp on the bale. Continue holding the Joystick Handle to the left until you are confident the bale is held tightly in the clamp.
4. Press and hold the Joystick Trigger to lift the Bale Clamp.
5. Release the Joystick Trigger as soon as the bale has traveled past the center of gravity to allow the bale to fall gently onto the Receiving Table.
6. Once the bale is resting on the Receiving Table, move the Joystick Handle to the right to open the Bale Clamp.
7. Press and hold the Joystick Trigger to raise the Bale Clamp off the Receiving Table.
8. Release the Joystick Trigger once the Bale Clamp has passed the center of gravity to allow the Bale Clamp to fall toward the ground.

9. Once the Bale Clamp is safely out of the way from the Receiving Table, pull the Receiving Table Grip back to raise the Receiving Table.
10. Once the Receiving Table is half way up and the bale has slid to the rear of the Receiving Table, press the Receiving Table Grip forward to lower the Receiving Table back down. If the Receiving Table is has the maximum number of bales on it, raise the Receiving Table all the way up to transfer the bales from the Receiving Table to the Stack Bed before lowering it back down.
11. Continue loading bales until the Stack Bed is completely full. When stacking 3x3 bales, the Stack bed will hold 18 bales. If you are stacking 3x4 bales, the stack bed will hold 12 bales. If you are stacking 4x4 bales, the Stack Bed will hold 8 bales.
12. Once the PT/2016 is fully loaded and the Receiving Table is completely down, repeat steps 4 & 5 to place the Bale Clamp in the up position, resting above the Receiving Table.
13. Center the Hitch by pulling the Joystick Handle back before driving to the location where you will unload the PT/2016. Once the Hitch is centered, release the Joystick Handle.

You are now ready to drive to the stacking location and begin the Manual Unloading Sequence.



## **Unloading in Automatic Mode**

Unloading the PT/2016 in automatic mode has been implemented in such a way as to allow the operator to focus lining up with an existing stack while the PT/2016 prepares to unload. The following steps will walk you through unloading the PT/2016 in Automatic Mode.

1. Once you are ready to back up to an existing stack or start a new stack, pull the Stack Bed Grip backwards and hold it until the Stack Bed automatically begins to lift. The Stack Bed will continue to lift until the Stack Bed is almost touching the ground.
2. While the Stack Bed is lifting, it is safe to begin backing up to the existing stack or where you would like to start a new stack.
3. Shifting the Hitch to the left will align the left side of the PT/2016 with the center of your tractor, making it easier to make a straight stack. To shift the Hitch to the left, push the Joystick Handle forward.
4. Once you have the PT/2016 where you would like to unload, gently pull the Stack Bed Grip backwards gently to lower the load down to the ground. The Stack Bed Grip is a proportional control, meaning that the farther you move the grip from its center position, the faster it will command the hydraulic cylinders to move.
5. When the load is standing straight up, slowly pull away from the stack until the Rolling Rack has completely pulled out from under the stack.
6. After the Rolling Rack is completely out from under the stack, press and release the Automatic Unload Reset button on the Joystick. This will lower the Stack Bed, center the Hitch, and move the Rolling Rack forward as you drive through the field to your next bales. Once you press the Automatic Unload Reset button on the Joystick, the computer adds the number of bales that were on Stack Bed to the Customer Count then clears the Stack Bed count.

## **Unloading in Manual Mode**

The steps taken to unload the PT/2016 manually are similar to unloading automatically with the exception of having to control each function manually. The following steps are necessary to unload manually:

1. Once you are ready to back up to an existing stack or start a new stack, pull the Stack Bed Grip backwards and hold it until the Stack Bed is almost touching the ground. The Stack Bed Grip is a proportional control, the farther you move the grip, the faster the Stack Bed will move.
2. Shifting the Hitch to the left will align the left side of the PT/2016 with the center of your tractor, making it easier to make a straight stack. To shift the Hitch to the left, push the Joystick Handle forward.
3. Once you have the PT/2016 where you would like to unload, pull the Stack Bed Grip backwards gently to lower the load down to the ground.
4. When the load is standing straight up, slowly pull away from the stack until the Rolling Rack has completely pulled out from under the stack.
5. After the Rolling Rack is completely out from under the stack, press the Stack Bed Grip forward until the Stack Bed is completely down.
6. Once the Stack Bed is down, pull the Joystick Handle backward until the Hitch is completely centered.
7. Push the Rolling Rack 3-Way Switch forward until the Rolling Rack is completely forward.
8. Press the Clear Stack Bed button on the Totals Screen to add the Load Count to the Customer Count. This will also clear the load count. If the Count In Manual Mode option is turned on, you may press the Automatic Unload Reset button on the Joystick to add the Stack Bed Count to the Customer Count and clear the Stack Bed count instead of navigating to the total screen.

## **Bale Count Adjustment**

If at any time you find it necessary to adjust the counts on the Stack Bed or Receiving Table, you can do so on the Display.

### **Adjust Receiving Table Count**

To adjust the Receiving Table Count, navigate to the Loading Screen then press the Counts button. Once on the Counts Screen, press the Receiving Table Add button. Each time you press this button one bale will be added to the Receiving Table count. If the Receiving Table is full and the Receiving Table Add button is pressed, the Receiving Table Count will reset to zero.

Each time you change the Receiving Table count using the Display, the PT/2016 will be placed into manual mode and will need to be switched back into automatic mode before continue to load.

Once the PT/2016 is switched back to Automatic mode, the Receiving Table will raise either half way or all the way up depending on the Receiving Table Count. This ensures that the bales are properly situated on the Receiving Table to avoid stacking two bales on top of each other on the Receiving Table.

### **Adjust Stack Bed Count**

To adjust the Stack Bed count, navigate to the Loading Screen then press the Counts button. Once on the Counts Screen, press the Stack Bed Add or Subtract button. This will add or subtract a bale to or from the Stack Bed respectively.

If you would like to clear the Stack Bed Count, navigate to the Totals Screen and press the Clear Stack Bed button on the Display. Using the Clear Stack Bed button will also add the number of bales from the Stack Bed Count to the Customer Count in Automatic Mode or if in Manual Mode and the Count In Manual Mode option is turned on.

### **Clear Customer Count**

To clear the customer count, navigate to the Totals Screen and press the Clear Customer button.

# Lubrication

---

Lubrication of the PT/2016 joints is vital to ensuring a long and successful lifespan of your machine. It is important to follow a strict lubrication schedule to prevent excessive wear and corrosion.

#	Description	10 Hours	Daily
1	Right Arm Pivot - Top	X	
2	Right Arm Pivot - Bottom	X	
3	Bale Load Cylinder - Front	*see note	
4	Bale Load Pivot Bearing - Right	X	
5	Bale Load Pivot Bearing - Left	X	
6	Bale Load Cylinder - Rear	X	
7	Hitch Bearing - Top		X
8	Hitch Bearing - Bottom		X
9	Receiving Table Pivot - Right	X	
10	Receiving Table Pivot - Left	X	
11	Receiving Table Cylinder - Rear, Left		X
12	Receiving Table Cylinder - Front, Left	X	
13	Receiving Table Cylinder - Rear, Right		X
14	Receiving Table Cylinder - Front, Right	X	
15	Stack Bed Pivot - Right		X
16	Stack Bed Pivot - Left		X
17	Hitch Ball		X
18	Pushoff Pivot		X

\*critical service point - must be greased every 5 hours or 360 bales, whichever comes first.

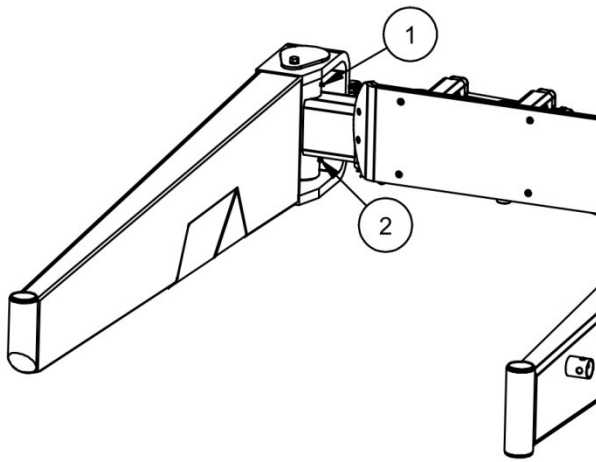

- 1. Right Arm Pivot - Top
- 2. Right Arm Pivot - Bottom

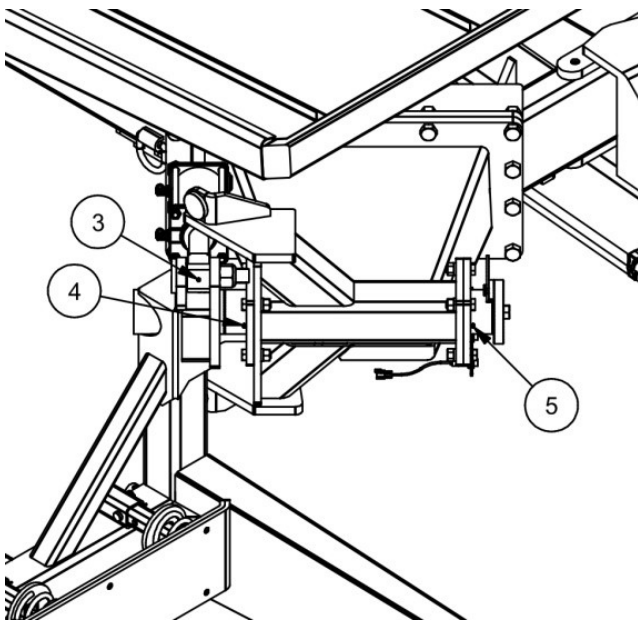

- 3. Bale Load Cylinder - Front
- 4. Bale Load Pivot Bearing - Right
- 5. Bale Load Pivot Bearing - Left

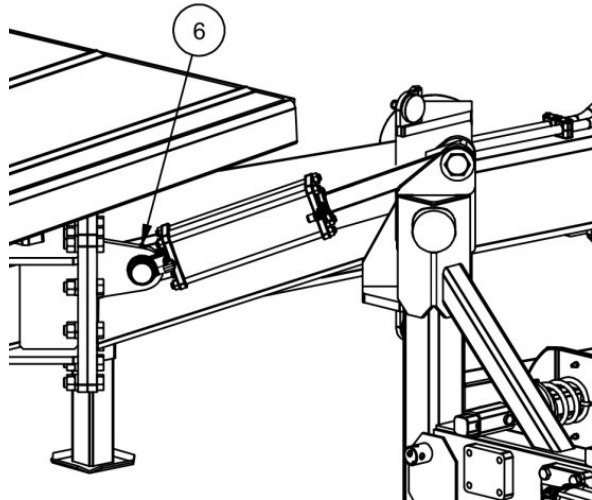

6. Bale Load Cylinder - Rear

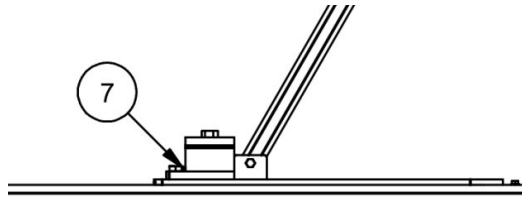

7. Hitch Bearing - Top

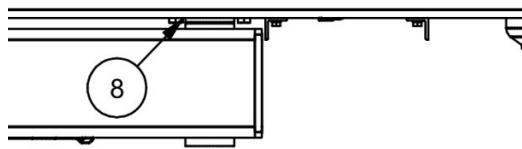

8. Hitch Bearing - Bottom

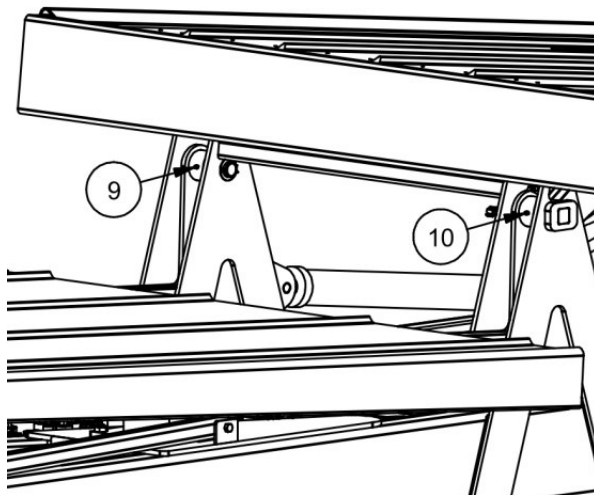

9. Receiving Table Pivot - Right

10. Receiving Table Pivot - Left

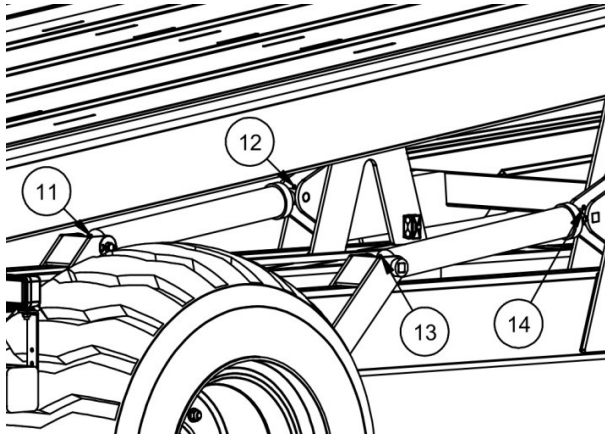

- 11. Receiving Table Cylinder – Rear, Left
- 12. Receiving Table Cylinder – Front, Left
- 13. Receiving Table Cylinder – Rear, Right
- 14. Receiving Table Cylinder – Front, Right

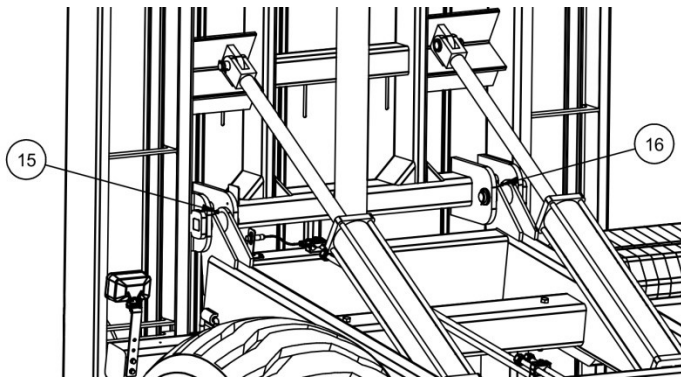

- 15. Stack Bed Pivot – Right
- 16. Stack Bed Pivot – Left

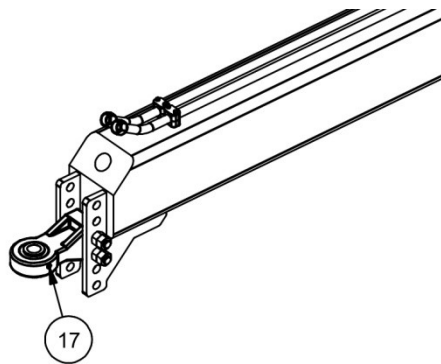

- 17. Hitch Ball

# Maintenance

---

Following a proper maintenance schedule is important to insure successful operation of your PT/2016 for years to come. The following maintenance section will help keep your PT/2016 working at optimal efficiency and prevent down time due to repairs.

## Maintenance Chart

Service Interval	Machine Part	Maintenance Operation
Every 10 Hours or Daily	Pivot Joints	Lubricate with grease
	Entire PT/2016	Remove dirt and debris
As Required	Wheel lug nuts	Torque to 420 ft-lb
Every 50 Hours	Tire Pressure	Check and Adjust to 36 PSI Max
	Hydraulic Hoses	Check for wear/replace if needed
Every 1000 Hours	Hydraulic Filter Element	Change

## Cleaning

Clean the entire PT/2016 daily using compressed air to quickly remove debris. An oil and debris covered machine is a fire hazard. Dirt and debris can work into joints, wearing them out more quickly.



## **First 50 Hours**

After the first 50 hours of operation it is important to perform the following maintenance. Failure to do so can cause damage to the PT/2016.

- 1) Inspect hydraulic system filter and change if necessary.
- 2) Ensure tires are inflated to the tire manufactures recommendation
- 3) Torque wheel lug nuts to 420 ft-lb.

# Troubleshooting

---

This section will help you work through common problems which may occur if the PT/2016 is not adjusted properly.

**When working on or adjusting any component of the PT/2016, make sure all safety stops are in place, all moving parts are secured in place to prevent movement, the tractor is turned off, and all power and hydraulics are disconnected. Failure to do so can result in personal injury or death as well as damage to the PT/2016 and tractor.**

When a sensor's state needs to be checked, you can do so by navigating to the Totals Screen on the Display then pressing the Setup button. Once on the Setup Screen, press the Next button until the selection indicator is in line with the Sensor Values option then press the Enter button. You will now see the following screen:

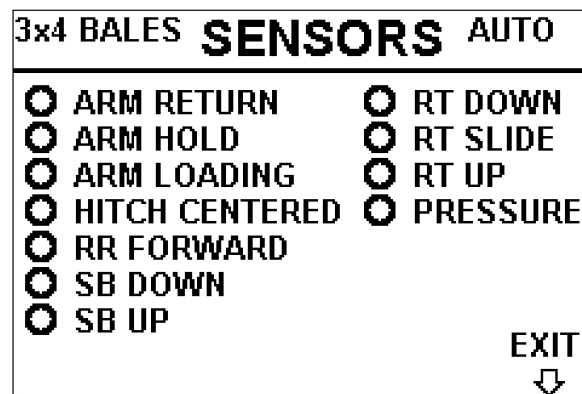

The Sensors Screen allows you to view the status of all the sensors on the PT/2016. A solid circle indicates that a sensor is detecting a sensor target in front of it and a hollow circle indicates that a sensor is not detecting a target in front of it. This information allows you to see what state the sensors are in without having to leave the tractor cab.

## Bale Clamp

Symptom	Cause	Fix
Bale Clamp begins to lift before the bale is securely squeezed in the clamp.	Pressure Switch is set too low.	Rotate Pressure Switch adjustment housing clockwise ½ turn at a time to increase the pressure needed for the Pressure Switch to turn on.
Bale Clamp will not lift after squeezing bale.	PT/2016 is not in Automatic Mode.	Ensure PT/2016 is in Automatic Mode.
	Bale Clamp (Arm) Sensor Target or Return sensor is not adjusted properly.	Ensure Arm Sensor Target and Return sensor are adjusted so that the Arm Return Sensor is not lit when Bale Clamp is down.
	Pressure Switch is set too high.	Rotate Pressure Switch adjustment housing counter- clockwise ½ turn at a time to decrease the pressure needed for the Pressure Switch to turn on.
Bale Clamp places bales onto the Receiving Table too quickly.	Cushion Valve is set too low.	Rotate the Cushion Valve adjustment screw clockwise to increase the flow restriction of the Cushion Valve.
Bale Clamp lowers bales onto the Receiving Table too slowly.	Cushion Valve is set too high.	Rotate the Cushion Valve adjustment screw counter-clockwise to decrease the flow restriction of the Cushion Valve.
Bale Clamp chatters when squeezing bale.	Pressure Switch is set too low	Rotate Pressure Switch adjustment housing clockwise ½ turn at a time to increase the pressure needed for the Pressure Switch to turn on.

<b>Bale Clamp stops at the top dead center position and will not swing over the rest of the way.</b>	The Bale Clamp (Arm) Loading Sensor is not adjusted properly.	Adjust the Bale Clamp (Arm) Loading Sensor to adjust the top dead center position.
	Cushion Valve is set too high.	Rotate the Cushion Valve adjustment screw counter clockwise to decrease the flow restriction of the Cushion Valve.

### Receiving Table

<b>Symptom</b>	<b>Cause</b>	<b>Fix</b>
<b>Receiving Table will not raise or lower in manual mode.</b>	Bale Clamp is not in the down position. The PT/2016 attempts to prevent the Receiving Table from colliding with the Bale Clamp.	Ensure the Bale Clamp is in the down position before attempting to move the Receiving Table up or down.
<b>Receiving Table will not lift after placing a bale on the Receiving Table in automatic mode.</b>	Stack Bed is not down. The PT/2016 attempts to prevent the Receiving Table from dumping bales underneath the Stack Bed.	Lower the Stack Bed all the way down. If the Stack Bed is all the way down, check to make sure the Stack Bed Down sensor is adjusted properly and is lit up when the Stack Bed is down.
<b>Receiving Table lifts up and transfers bales from the Receiving Table to the Stack Bed but does not lower back down.</b>	The Receiving Table Up Sensor is set too high and the Receiving Table cylinders reach maximum stroke before the Receiving Table Target reaches the Receiving Table Up Sensor.	Move the Receiving Table Up Sensor so the Receiving Table Sensor Target reaches the Receiving Table Up Sensor before the cylinders reach maximum stroke.

## Stack Bed

Symptom	Cause	Fix
Stack Bed does not stop after initiating the Automatic Unload Lift sequence.	The Stack Bed Up Sensor is not adjusted properly	Adjust the Stack Bed Up Sensor so it is lit when the Stack Bed is about 3–5 inches from touching the ground.
Stack Bed does not stop when the Automatic Unload Reset sequence is initiated.	The Stack Bed Down Sensor is not adjusted properly	Adjust the Stack Bed Down Sensor so it is lit when the front of the Stack Bed is in the down position and resting on the Stack Bed Rest.

## Rolling Rack

Symptom	Cause	Fix
Rolling Rack will not allow bales to slide back easily.	The Rolling Rack Low Pressure Relief is set too high.	Turn the Rolling Rack Low Pressure Relief adjustment screw counter clockwise to reduce the amount of pressure needed to allow the Rolling Rack to slide back.
Rolling Rack rolls away from the bales on the Stack Bed.	The Rolling Rack Low Pressure Relief is set too low.	Turn the Rolling Rack Low Pressure Relief adjustment screw clockwise to increase the amount of pressure needed to allow the Rolling Rack to slide back.
Once the Rolling Rack is all the way forward, it continues to try to move during the Automatic Unload Reset sequence.	The Rolling Rack Forward Sensor is not adjusted properly.	Adjust the Rolling Rack Forward Sensor so it is lit when the Rolling Rack is in the forward position.

## Hitch

Symptom	Cause	Fix
Hitch does not stop trying to center after it has reached the center position when the Automatic Unload Reset sequence has been initiated.	The Hitch Center Sensor is not adjusted properly.	Adjust the Hitch Center Sensor so it is lit when the Hitch is in the centered position.

---